

Streetscape Map

STEP 1 Find the Streetscape Type for your parcel

Streetscape Types

- Urban Brick (Type 1)
- Urban Concrete with Brick (Type 2)
- Urban Concrete (Type 3)
- Neighborhood (Type 4)
- Parkway (Type 5)
- Capitol Boulevard (Type 6)
- Special / T.B.D. (Type 7)
- Celebratory Corners (Type 8)
- Possible Street Connections
- Existing & Proposed District Boundaries

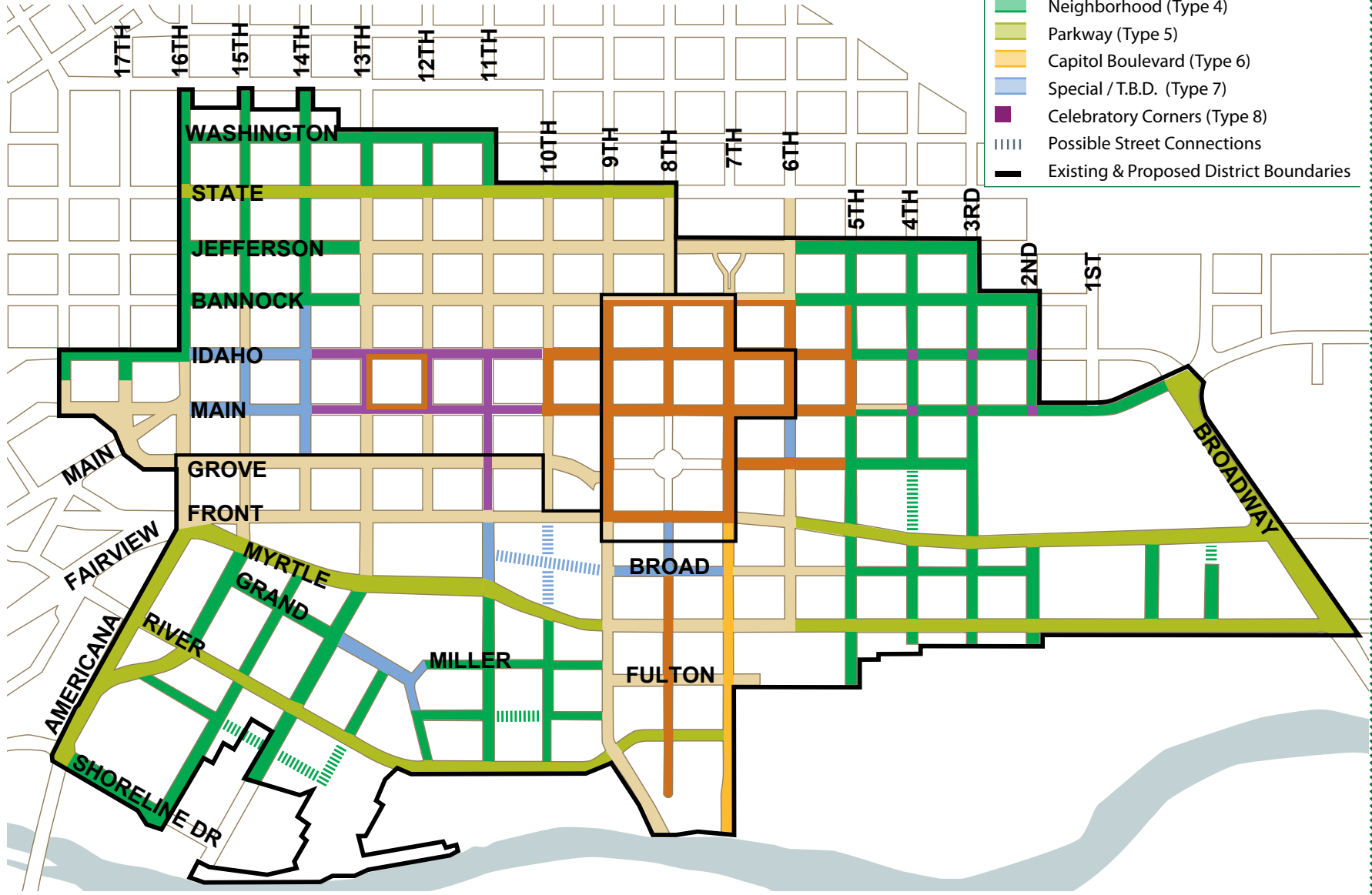

STEP **2** Streetscape Standards for your Streetscape Type

Urban Concrete (narrow)

For Sidewalk Right-of-Way of less than 16'

Urban Concrete Streetscape is generally located in business and mixed-use districts where there is a concentration of higher intensity development, ground floor retail, restaurants and entertainment uses and on-street parking.

It is designed for heavy pedestrian use and to be compatible with retail or similar uses in a dense urban environment. It may also be used with offices and housing at street level when such uses are located in business or mixed-use districts rather than neighborhoods.

Urban Concrete Narrow Streetscape is an alternate design to the wide urban sidewalk to be applied in areas where the existing sidewalk, from building to face of curb, is less than 16' and where decreasing the width of the roadway (relocating the curb) is not appropriate or feasible.

Hardscape Requirements

- Concrete
 - 4' modular scored concrete extends from building face to furnishing zone. 2' modular scored concrete in the furnishing zone.
 - Pedestrian zones: Concrete in pedestrian zone with parallel and cross scores at 4' intervals. No parallel scores are made within 6" of building foundation.
 - Furnishing zone: Concrete in Furnishing zone is scored in 2' intervals.
 - Pedestrian ramps at crosswalk are typically concrete with truncated domes.
- Tree Grates and Framespages 6,7
 - 6x6 tree grates and frame should be installed.
 - 4x8 tree grates and frame should be installed in sidewalks less than 12' 6".
- Historic Street Lights.....pages 10,11
 - Spacing: Approximately 60' separation and in same alignment as trees. Lights should be centered between trees and conflicts with trees should be avoided.
 - Installation: Coordinate with Boise City Public Works Department, 384-3900.

Required Landscape

- Street Trees.....pages 7,12
 - Street Trees - Class II trees in furnishing zone (overhead power lines may limit tree species to Class I type) and in same alignment as Historic Street Lights. Trees should be spaced approximately 30' apart and installed in tree wells. Coordinate planning and installation of trees with Boise City Community Forestry, 384-4083.
- Drip Irrigationpage 12

Type 3

Locational Furnishings

Number and location of furnishings will be determined by CCDC through design review, and may include:

- Bench..... page 14
- Litter Receptacle page 15
- Bike Rack.....pages 16,17
- Movable Planters.....pages 18,19

Note:

The dimensions of the pedestrian zone and frontage zone will vary with overall sidewalk width.

Furnishings and street trees shall meet Ada County Highway District sight distance requirements.

All furnishings, trees and improvements in the street right-of-way require a license agreement and/or other form of approval by the Ada County Highway District, 387-6170.

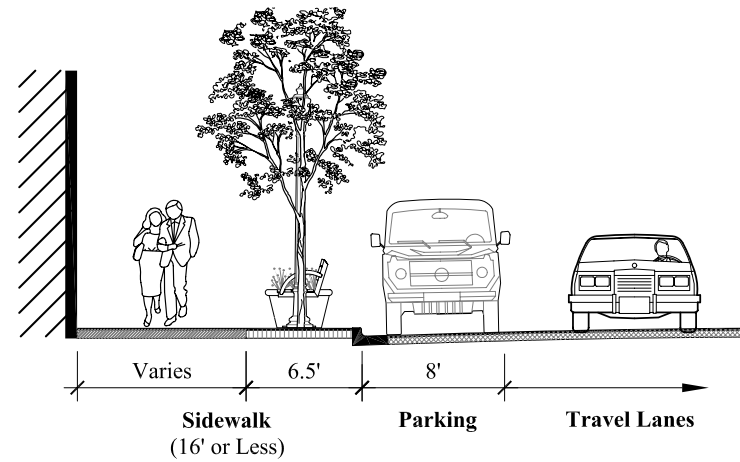

NARROW URBAN SIDEWALK SECTION

NOT TO SCALE

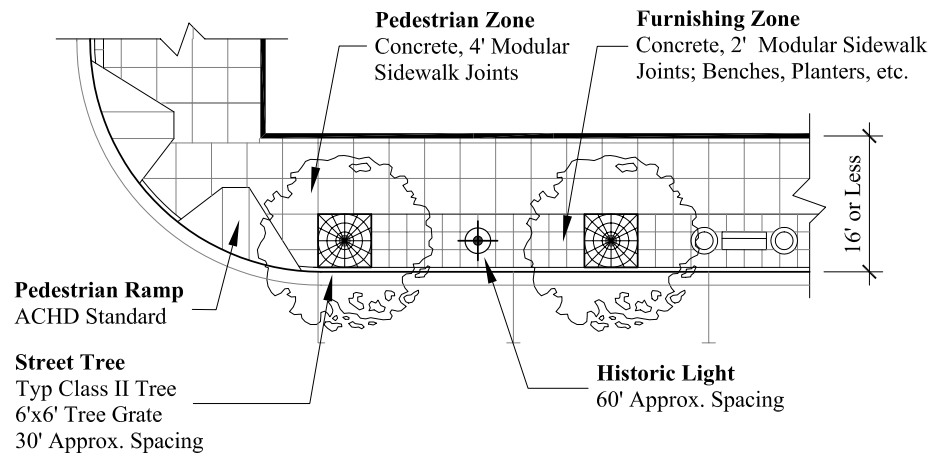

NARROW URBAN SIDEWALK DETAIL PLAN

SCALE 1"=20'

STEP **3** Specifications for your Streetscape Type



Streetscape Specifications

Hardscape Specifications:

- Tree Grates and Frames..... page 6
- Tree Wells & Tree Planting page 7
- Trench Grates & Slotted Drainspages 8,9
- Historic Street Lights & Instalationpages10,11

Landscape Installation Guidelines:

- Landscape Installation.....page12
- Tree Planting in Sodpage13

Locational Furnishings Specifications:

- Benchespage14
- Litter Receptaclepage15
- Bicycle Racks..... pages16, 17
- Movable Planters..... page18, 19

Tree Grates & Frames

Street trees are selected to provide visual continuity along a single block face by using the same species. When planting new street trees, the trees should be the same species, of a similar caliper (size) and placed at a consistent and even spacing within the block face. When replacing a sick or dead tree, the new tree should be the same species of the other street trees on the block unless otherwise specified and should be the largest caliper appropriate to facilitate continuity along the block face. Consult Boise City Community Forestry for tree species, and before you plant, prune or remove a tree, 384-4083.

Tree grates and frames should be "Kiva" 6'x6' or 4'x8'; cast iron tree grates, as manufactured by Urban Accessories, Tacoma, Washington. Grates shall be natural finish without powdercoating or paint. Grates shall meet ADA standards.

Tree Grate and Frame order information:

6 foot square or 4 foot by 8 foot rectangular cast iron "Kiva" model grate and frame by Urban Accessories, Tacoma, Washington (or its equivalent as approved by CCDC). Regional representative is Northwest Recreation, (800) 448-4858.

Order frame type "S" Standard, "A" Adjustable or "R" Retro as required.



Trench Grates

Trench grates may be used for slotted drains. These grates should be cast iron in the "Tidal Wave" pattern, as manufactured by Urban Accessories.
Other trench grates may be approved by CCDC.

Trench Grate order information:

6" wide "Wave" pattern by Urban Accessories, Tacoma, Washington (or its equivalent as approved by CCDC). Regional representative is Northwest Recreation, (800) 448-4858.



Slotted Drains

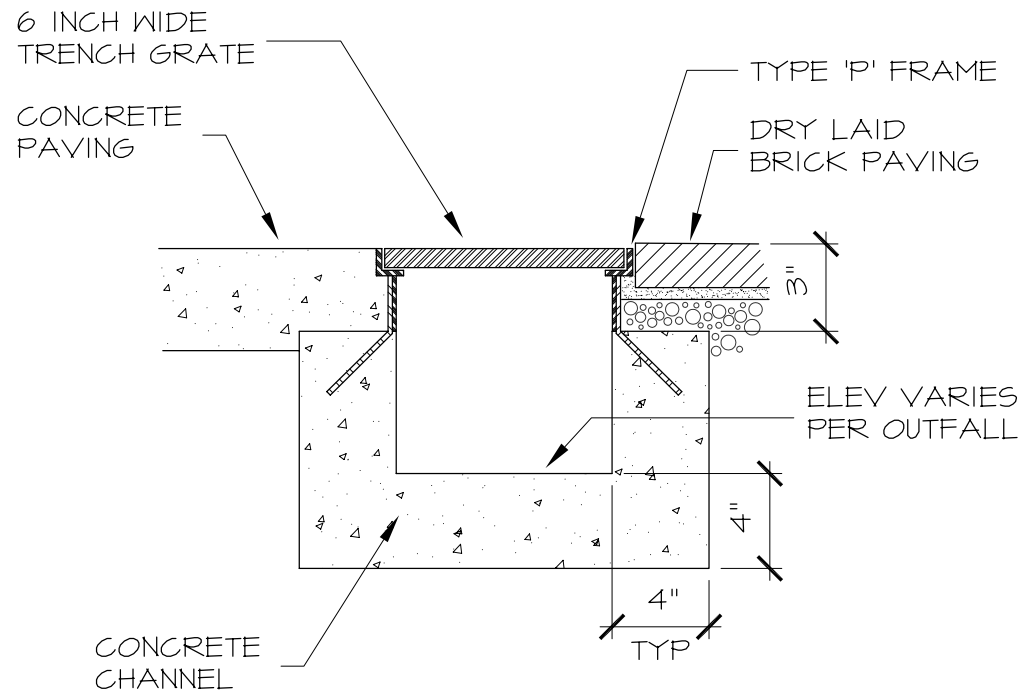

Hardscape Specifications

Historic Street Light

Pole top lighting fixtures should be placed centrally in the furnishing zone and location and spacing shall be approximately 60' apart (or as approved by Boise City Public Works Department), and in same alignment as trees. Lights should be centered between trees and conflicts with trees should be avoided. Historic Boise cast iron light poles should be used, or cast aluminum (not fiberglass) replication. The metal shall be powdercoated green (RAL 6009).

See Boise City's website at: http://www.cityofboise.org/Departments/Public_Works/PDF/SLstandardspecs81006.pdf (page 12) for Public Works historic streetlight specifications.

Contact the Downtown Boise Association 208-472-5250 about brackets for banners on the lighting fixtures.

Historic Street Light order information:

Boise Series 12.5 foot high fluted cast aluminum post with provision for photocell, custom logo and 3-inch tenon mount for luminaire by Antique Street Lamps, Austin, TX, (512) 977-8444. Or Hinkley Lighting, Cleveland, OH (216) 671-3300 (or its equivalent as approved by CCDC). Color RAL 6009.

Luminaire to be Holophane Granville 150 W.H.P.S. (GV15AHPMTAN7NNU) Hinkley-Glass Acorn No. 70357/HPS/150/MT (With Night Sky Reflector)



Historic Street Light Installation

Hardscape
Specifications

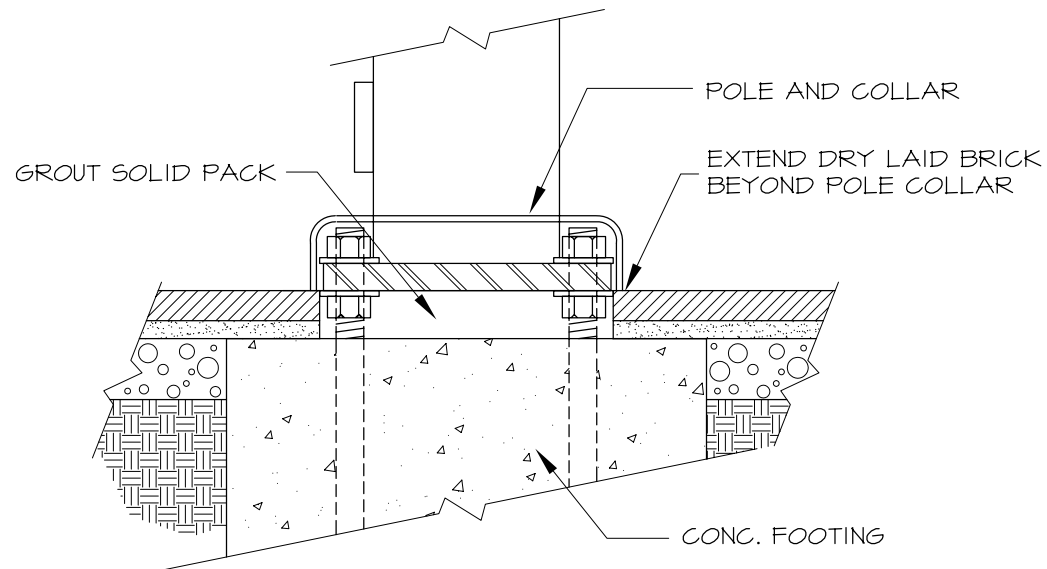

ALL FOOTINGS AND CONCRETE SURROUNDS ARE
REQUIRED TO BE CONCEALED WITH A COLLAR
OR BASE PLATE.

Landscape Installation

Street Trees

Trees must be selected by Boise City Community Forestry. A Boise City Forester will select the classification (size) and species appropriate to each project. Street trees must have a 2-1/2 inch minimum trunk diameter at the time of installation, be balled and burlapped, and be well formed with no branches below 6 feet height in pedestrian use areas. Trees must be nursery grown and installed by a qualified landscape professional. Planting soil must be a well draining blend of pH balanced topsoil and composted amendments. Street trees must be watered from an automatic irrigation system, with drip tubing for tree wells, and pop-up sprinklers for trees in lawn strips.

Landscape Irrigation

All street trees and landscaping must be watered with an automatic underground irrigation system. Hookup must be in compliance with local plumbing codes for protection of the domestic water supply. The system must be designed and installed by a qualified landscape professional utilizing water conservation techniques. All supply piping under paved surfaces must be inside rigid conduit and all valves in the public right-of-way must be in traffic rated boxes. The system must include provision for winterization.

Lawn Sod

Provide lawn sod composed of 80% Bluegrass varieties and 20% Perennial Ryegrass, delivered from a certified sod grower at the time of planting. Preparation of the planting soil will consist of placing a 6 inch well draining blend of pH balanced topsoil and composted amendments. The soil must not be saturated or frozen. Install the sprinkler circuit for complete coverage either before or after soil preparation, and finish grade the surface from sidewalk to curb elevation minus 1-1/2 inch to account for the sod thickness. Lightly moisten the soil surface. Lay the sod in unbroken strips with tight joints, fertilize, and irrigate thoroughly.

Tree Planting in Sod

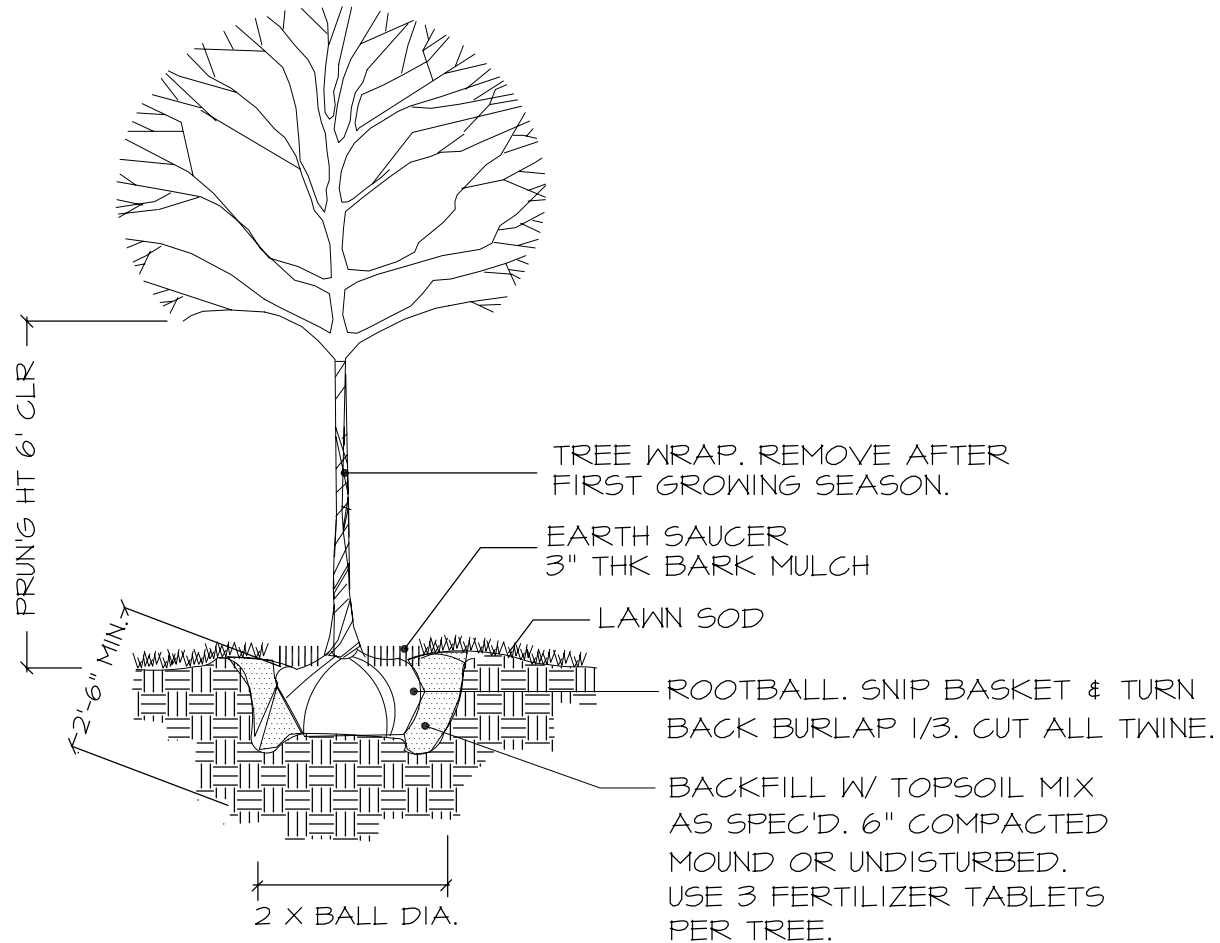

Situational
Furnishings

Benches

Benches are used in various configurations in the pedestrian furnishing zone. Benches placed parallel to the street (facing either toward the street or toward the building frontage) are typically four or five feet. Five feet is the typical length for benches facing each other and placed perpendicular to the street. Lengths greater than five feet shall not be used.

Benches have cast iron ends with wooden slats. A wood alternative for the slats may be used with approval from CCDC.

Location in the furnishing zone shall be as approved by CCDC or as shown on a streetscape plan approved by CCDC.

Surface mount with 1/2 inch by 2-inch expansion bolts.

**Bench order information:**

4 or 5 foot length, cast iron with wooden slats. "Boston Bench Model B-76D" by Boston Bench Concord, MA, (978-287-9580) (or its equivalent as approved by CCDC). Color RAL 6009.

Litter Receptacles

Situational
Furnishings

Litter receptacles should be placed near seating areas and street corners where there is a high volume of pedestrian traffic. Location in the furnishing zone shall be as approved by CCDC or as shown on a streetscape plan approved by CCDC.

Previous trash receptacles “Radius” style from DuraArt Stone are still in use, but will be replaced with Chase Park Litter receptacles over time as resources are available. Replacement lids for Radius receptacles shall be the standard composite lid (Fiberlite) sized to fit “Standard” base as manufactured by DuraArt Stone, Pasadena, Calif. (800) 821-1120; color should be copper.



Litter Receptacle order information:

Chase Park model, side opening, with 36 gallon black polyethylene liner by Landscape Forms, Kalamazoo, MI. (800) 521-2546.
Powdercoat color RAL 6009 by Manufacturer. Surface mount with 3/8-inch anchor bolts (provided).

Situational
Furnishings

Bike Rack

Bicycle racks should be located in the pedestrian furnishings zone at locations throughout developments which attract cyclists. Bike racks should be the wave model in one or three bends. Number of bends determined by CCDC.

Location in the furnishing zone shall be as approved by CCDC or as shown on a streetscape plan approved by CCDC.



Bicycle Rack order information:

Ribbon Rack - one or three bend. Manufactured by Pacific Steel Fabricators, (208) 362-0098 (or its equivalent as approved by CCDC). Color RAL 6009.

Bike Rack Installation

Situational Furnishings

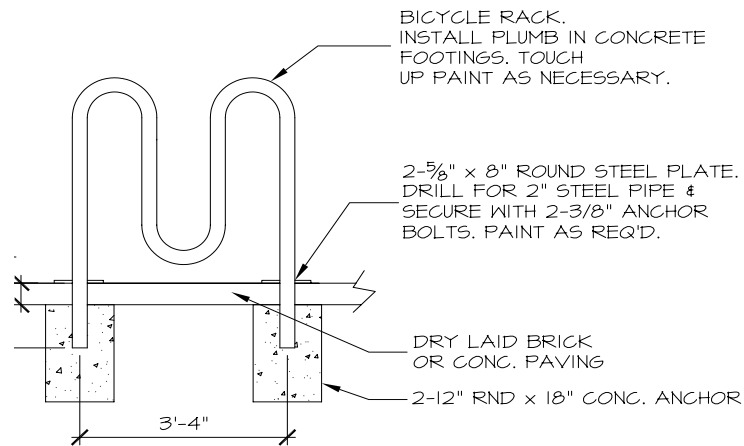

BIKE RACK: 'RIBBON RACK', DIRECT BURY, AS PROVIDED BY PACIFIC STEEL FABRICATORS, (208-362-0098), OR EQUAL. POWDERCOAT RAL-6009.

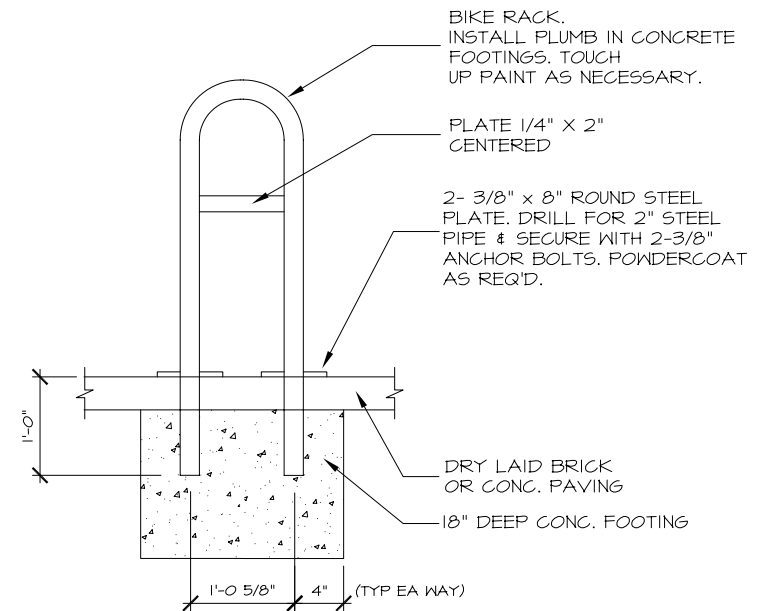

BIKE RACK: 'RIBBON RACK SINGLE', AS PROVIDED BY PACIFIC STEEL FABRICATORS, (208-362-0098), OR EQUAL. POWDERCOAT RAL-6009.

Situational
Furnishings

Movable Planter

Movable planters shall be 3' in diameter and 17" high or as approved by CCDC. Location in the furnishing zone and spacing shall be as approved by CCDC or as shown on a streetscape plan approved by CCDC.

The Downtown Boise Association manages the flower program for the downtown Boise business improvement district (South of State Street, North of Myrtle Street, East of 13th and West of 5th Street). Planters are filled with flowers from May through November and are paid for by the annual merchant assessment funds after the first year's dues are paid by property owner, unless special arrangements are made with the DBA.

Contact the DBA for details about flower planting program, (208) 472-5250.



Movable Planter order information

CCDC Standard 3 foot round x 17 inch height cast stone planter by Idaho Precast Concrete, Nampa, ID, (208) 461-6300 (or its equivalent as approved by CCDC).

Movable Planter Installation

Situational
Furnishings

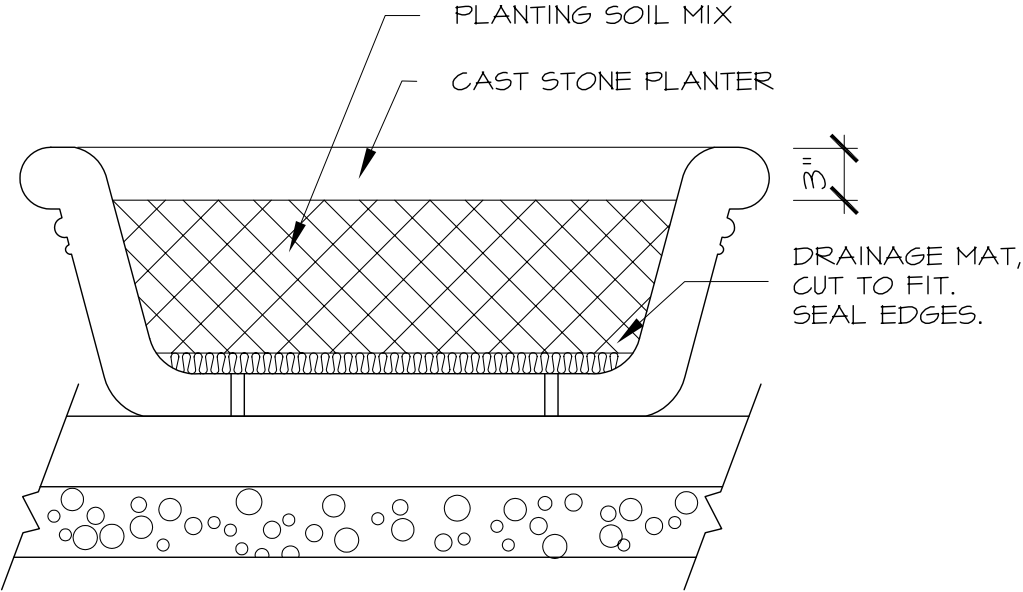

STEP **4** Quality control standards and conditions for your Streetscape project



Quality Control: Construction Standards & Conditions

All construction on this project shall conform to current IDAHO STANDARDS FOR PUBLIC WORKS CONSTRUCTION (ISPWC), ADA COUNTY HIGHWAY DISTRICT STANDARD SUPPLEMENTAL SPECIFICATIONS and Standard Drawings, and CITY OF BOISE SUPPLEMENTAL STANDARD SPECIFICATIONS.

The Streetscape Project shall be constructed in accordance with the overall City of Boise infrastructure plans, policies, and design standards and with this Downtown Boise Streetscape Standards Manual.

General Requirements

Construction Coordination

The Developer shall schedule and attend:

- A preconstruction meeting with CCDC and the general contractor to ensure an understanding as to the construction of the Streetscape Project.
- A mid-point and final construction inspection and meeting with CCDC and the general contractor to ensure that the Streetscape Project is constructed in accordance with the approved plan.
- The Contractor shall coordinate construction with Qwest Communications, United Water Idaho, Boise City Public Works Department, ACHD (signal interconnect), Idaho Power Company, and Intermountain Gas Company. Extreme care must be maintained when working in the vicinity of utility lines. The Contractor shall retain and protect all utilities, including electrical facilities, within the project limits not specifically identified for abandonment or relocation.
- The Contractor shall coordinate with these utilities, with ACHD and/or ITD, and their contractors as applies, and keep them informed of any schedule changes.

Working Hour Traffic

- Avoid disturbance of rush hour traffic between 7:00 to 8:00am and 4:00 to 6:00pm on all fronting streets.
- Contractor will be required to obtain Right-Of-Way Permits from Ada County Highway District (ACHD) and/or Idaho Transportation Department (ITD).

Contact Information

Project Manager for CCDC	Capital City Development Corp. Katina Dutton 384-4264
Street Light Coordination.....	Boise City Public Works Dept. Hank Alarcon 384-3900
Parking Meter Coordination.....	Boise City Parking Control John Eichmann 384-3745
Street Tree Coordination.....	Boise City Community Forestry Brian Jorgenson 384-4083
Fire Hydrants.....	Boise City Fire Department Dave Muir 384-3950
Work within Rights-of-Way	Ada County Highway District Chanon Romo 387-6170
Telephone	Qwest Communications Mark Hatfield 385-2144
Electric.....	Idaho Power Company Dave Stephens 388-5441
Gas	Intermountain Gas Company Greg Watkins 377-6846
Water Service, Valves.....	United Water Idaho Robert Jensen 362-7355

Construction Schedule

- In order to minimize impacts on existing businesses under renovation the Contractor shall conduct his operation to meet the following schedule:
 - Contractor shall restrict parking space closure to four spaces at any given time and only as authorized by Boise City 384-3745.
 - The Contractor and construction operation shall not prevent access to occupied businesses during business hours. Pedestrian access shall be provided to business during business hours, and in a safe direct manner at all times during construction. If it is necessary to interrupt access to any business, contractor shall obtain written permission -from the affected business, and notify the CCDC Project Manager 384-4264.

Contractor’s Responsibilities

- Coordinate Historic Street light installation with Hank Alarcon, Boise City Public Works, at least five working days prior to disruption of streetlights or circuits.
- All contract and adjacent areas impacted by construction shall be thoroughly cleaned at the completion of work.
- The contractor is responsible for obtaining permits, and/or paying for storage facilities during construction.

- It is the contractor’s responsibility for material pickup, delivery, and transport to the site.
- The contractor is responsible for providing water, electrical, and sanitary facilities for workers and construction activities.
- If the project has received a Streetscape Grant from CCDC, the contractor shall provide developer with itemized invoices for the items on the cost estimate submitted with the grant application.

Conditions of Grant Payment (if applicable)

- In accordance with the the Streetscape Grant Agreement:
 - Developer submits a Letter of Completion with invoices or receipts of streetscape work within thirty days of completion of the Streetscape Project.
 - CCDC performs a final streetscape inspection.
 - CCDC reviews and approves invoices. Grant is paid to developer within 90 days.

Go to www.ccdcboise.com for a streetscape grant application or call 384-4264.

Legal Disclaimer

The Streetscape Project shall be constructed in accordance with the overall City of Boise ("City") infrastructure plans, policies, and design standards and with the applicable portions of the Downtown Boise Streetscape Standards. The Downtown Boise Streetscape Standards and Downtown Boise Elements of Continuity have been adopted as follows:

- For streetscapes in the Central District, as Attachments No. 3F and 3G to the 2007 Amended and Restated Central District Urban Renewal Plan, adopted by the CCDC Board of Commissioners on March 15, 2007 by Resolution No. 1090 and by the Boise City Council on June 26, 2007 by Ordinance No. 6576; or as subsequently amended by CCDC Board of Commissioners.
- For streetscapes in the River Myrtle-Old Boise District, as Attachments No. 3B and 3C to the River Myrtle-Old Boise Urban Renewal Project Plan, adopted by the CCDC Board of Commissioners on August 23, 2004 by Resolution No. 1002 and by the Boise City Council on November 30, 2004 by Ordinance No. 6362; or as subsequently amended by CCDC Board of Commissioners.
- For streetscapes in the Westside Downtown District, as part of the Attachment No. 3 to the Westside Downtown Urban Renewal Project Plan (Westside Downtown Framework Master Plan - Section II: Design Standards), adopted by the CCDC Board of Commissioners on October 15, 2001 by Resolution No. 861 and by the Boise City Council on December 4, 2001 by Ordinance No. 6108; or as subsequently amended by CCDC Board of Commissioners.

This document does not modify or change the adopted Boise Streetscape Standards and Downtown Boise Elements of Continuity. If there is an inconsistency between this document and the adopted documents, the adopted documents prevail and should be used. Throughout this document, references are made to certain equipment, materials, or furnishings. Such items may be substituted by equivalent items as shall be approved in writing by CCDC. CCDC Board of Commissioners may subsequently modify those descriptions.